



For Lease: Industrial

# 4801 Steeles Avenue W

1,035 SF Industrial Unit Available in North York, ON

**Lennard:**

Here is where your business will *grow*.

[lennard.com](http://lennard.com)

# 4801 Steeles Avenue W



Prime industrial unit in a highly desirable North York location bordering Vaughan.



Available Space

**Unit 15 - 1,035 SF**

Industrial Area

**75% SF**

Office Area

**25% SF**



Zoning

**MC(H)**



Clear Height

**13'11"**



Possession

**Immediate**



Lease Rate

**\$3,600 Gross**

## Property Highlights

- Located in a well-established employment area on Steeles Ave W.
- Functional industrial layout suitable for a variety of permitted uses.
- Excellent connectivity to Highways 400, 401 & 407, and other major arterial roads.
- Accessible by local transit and situated within walking distance to numerous local amenities.

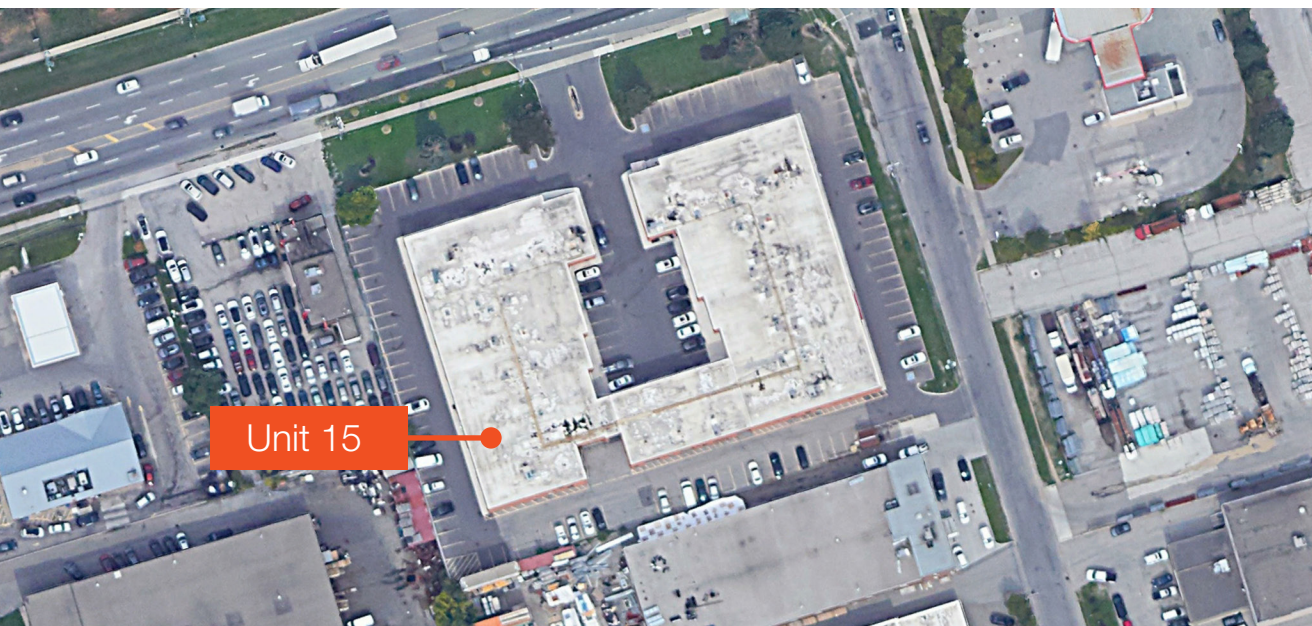

# 4801 Steeles Avenue W



## Unit 15 • Floor Plan

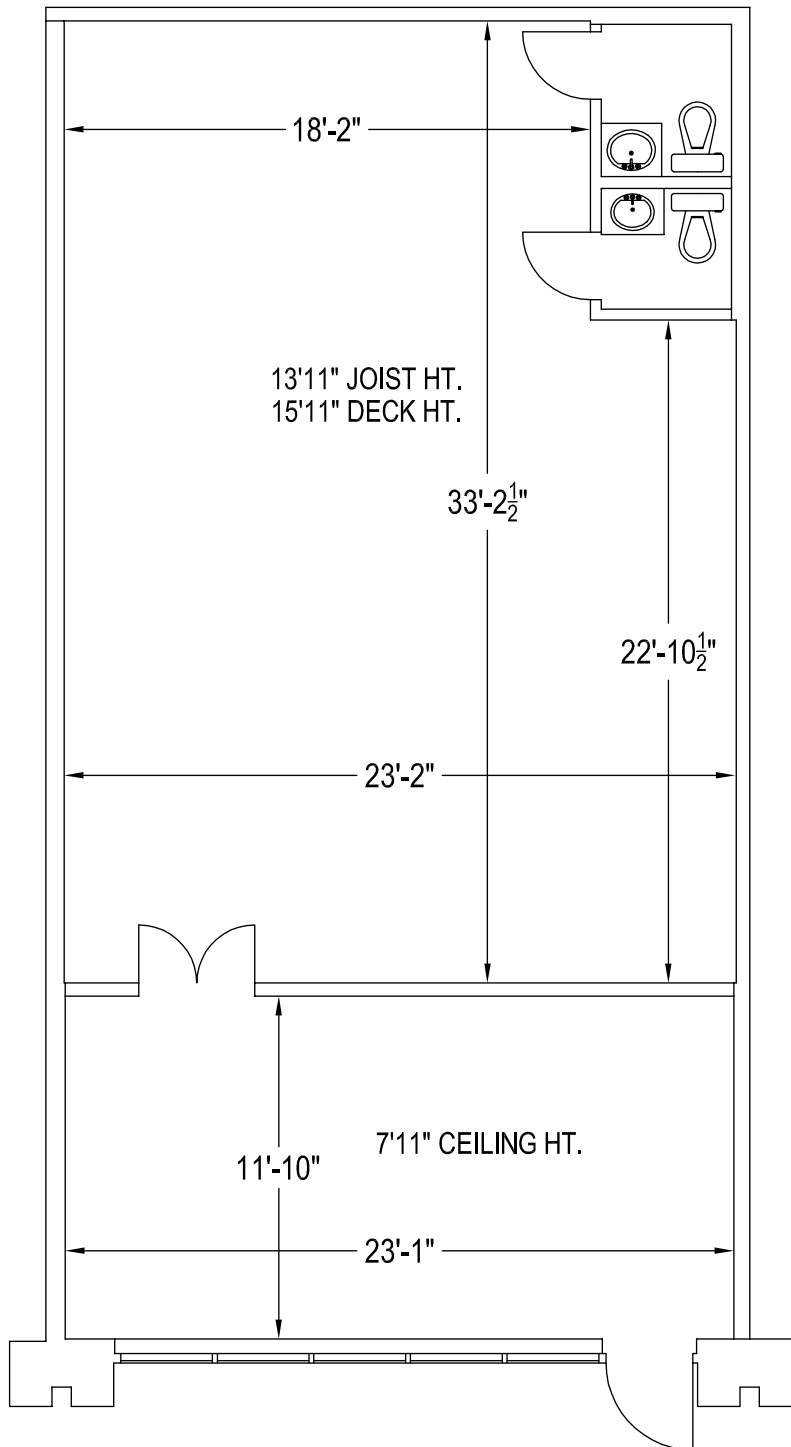

# 4801 Steeles Avenue W



## Zoning

### MC - Industrial-Commercial Zone

#### Permitted Uses:

- Adult Education school
- Artist Studio
- Banquet Hall
- Car Rental Agency
- Car Washing Establishment;
- Cinema
- Club
- College
- Commercial gallery
- Commercial Recreation
- Commercial School; Communications & Broadcasting; Community Centre
- Contractor's Establishment Custom Workshop
- Day Nursery
- Financial institution
- Fitness Centre
- Funeral Establishment
- Gasoline Station
- Golf Course
- Health Science Research Laboratory
- Hotel
- Industrial Sales & Service; Information Processing;
- Laundry
- Manufacturing
- Motor Vehicle Body Repair Shop;
- Motor Vehicle Dealership
- Museum;
- Office Uses
- Park
- Parking Lot
- Personal Service Shop
- Pinball & Video Games Arcade
- Place of Worship
- Public Library
- Public Self Storage Warehouse
- Research Laboratory
- Restaurant, with or without an outdoor patio
- Retail Stores
- Secondary School
- Service Shop
- Service Station
- Showroom
- Theatre
- Transportation Terminal
- Warehouse
- Veterinary Clinic

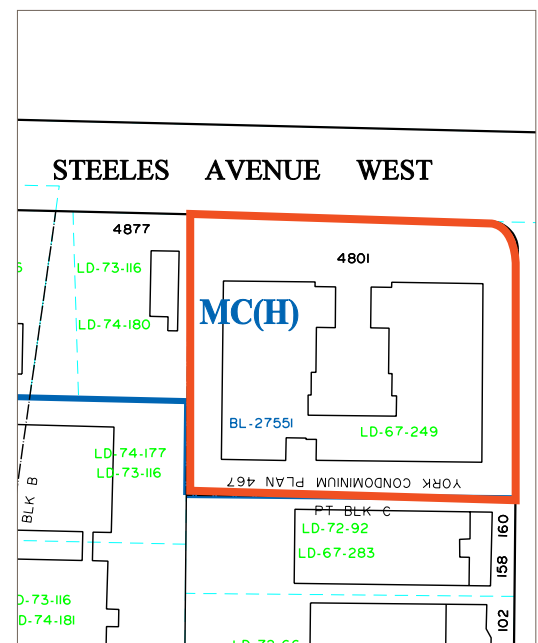

Source: City of North York By-Law No.7625

# 4801 Steeles Avenue W



## Amenity Map



# 4801 Steeles Avenue W



*A bright future for  
your business is  
right here.*



# Lennard:

**Andrew Holman\***  
Associate Vice President  
905.695.9170  
[aholman@lennard.com](mailto:aholman@lennard.com)

201-60 Columbia Way, Markham  
905.752.2220  
[lennard.com](http://lennard.com)

\*Sales Representative  
Statements and information contained herein are based on information furnished by principals and sources we deem reliable; however, we make no representation or warranty as to the accuracy, completeness or current status of such information and assume no responsibility for any errors, omissions, or misstatements. All information should be independently verified by the recipient. Lennard Commercial Realty, Brokerage.